



Regular and High Capacity HOPPER SPREADER

Owner's Manual



⚠ CAUTION

Read this manual and engine owner's manual
before installing or operating the spreader.

This manual is for FISHER® Regular and High Capacity Spreaders with serial numbers
(4997 -)

TABLE OF CONTENTS

PREFACE	1
SAFETY INFORMATION	2
Before You Begin	2
Torque Chart	3
Gasoline Warning Label	4
Warning/Caution Label	4
LOADING	5
Regular Capacity Load Weight	5
High Capacity Load Weight	5
Certification	5
Material Weights	5
Spreader Specifications	6
Determining Vehicle Payload	7
Determining Vehicle Payload	8
OPERATING THE SPREADER - STANDARD CAB CONTROL	9
Engine Operation	9
Starting the Engine	9
Stopping the Engine	9
OPERATING THE SPREADER - PREMIUM CAB CONTROL	10
Engine Operation	10
Starting the Engine	10
Stopping the Engine	10
OPERATING THE SPREADER	11
Choke Adjustment Procedure	11
Clutch Operation	11
Baffle Adjustment	11
Spread Patterns	12
MAINTENANCE	13
Grease	13
Chains	13
Electric Clutch	14
Fuel Filter Replacement	14
Engine Service and Repair	14
HYDRAULIC HOPPER SPREADER MAINTENANCE	15
After each use:	15
At the end of each season:	15
WIRING DIAGRAM (SPREADER BATTERY KIT)	16
WIRING DIAGRAM (VEHICLE BATTERY KIT)	17
ELECTRIC THROTTLE MOTOR REPLACEMENT	18
Removal Instructions	18
Installation Instructions	18

PREFACE

This manual has been prepared to acquaint you with the safety information, operation and maintenance of your new hopper spreader. Please read this manual carefully and follow all recommendations. This will help ensure profitable and trouble-free operation of your hopper spreader. Keep this manual accessible. It is a handy reference in case minor service is required.

When service is necessary, bring your hopper spreader to your local outlet. They know your spreader best and are interested in your complete satisfaction.

NOTE: This spreader is designed to spread snow and ice control materials only. Do not use it for purposes other than those specified in this manual.

SAFETY INFORMATION

⚠ WARNING

Indicates a potentially hazardous situation that, if not avoided, could result in death or personal injury.

⚠ CAUTION

Indicates a potentially hazardous situation that, if not avoided, could result in minor personal injury and/or damage to product or property.

NOTE: Identifies tips, helpful hints and maintenance information the owner/operator should know.

Before You Begin

- Park the vehicle on a level surface, place shift lever in PARK or NEUTRAL and set the parking brake.

⚠ WARNING

- Driver to keep bystanders minimum of 25 feet away from operating spreader.
- Before working with the spreader, secure all loose-fitting clothing and unrestrained hair.
- Before operating the spreader, verify all safety guards are in place.
- Before servicing the spreader, wait for conveyor or spinner to stop.
- Do not climb into or ride on spreader.

⚠ WARNING

Overloading could result in an accident or damage. Do not exceed GVWR or GAWR ratings as found on the driver-side door cornerpost of the vehicle. See Loading Section to determine maximum volumes of spreading material.

⚠ CAUTION

If rear directional, CHMSL light or brake stoplights are obstructed by the spreader, the lights shall be relocated, or auxiliary directional or brake stoplights shall be installed

⚠ CAUTION

During the hopper spreader installation we recommend the addition of an OSHA compliant Backup Alarm. This alarm is required for OSHA governed employers.

⚠ CAUTION

- Do not operate a spreader in need of maintenance.
- Before operating the spreader, reassemble any parts or hardware removed for cleaning or adjusting.
- Before operating the spreader, remove materials such as cleaning rags, brushes, and hand tools from the spreader.
- Before operating the spreader, read the engine owner's manual.
- While operating the spreader, use auxiliary warning lights, except when prohibited by law.
- Tighten all fasteners according to the Torque Chart. Refer to Torque Chart for the recommended torque values.

⚠ CAUTION

Disconnect electric power before servicing or performing maintenance.

⚠ CAUTION

DO NOT leave unused material in hopper. Material can freeze or solidify, causing unit to not work properly. Empty and clean after each use.

NOTE: Lubricate grease fittings after each use. Use a low temperature synthetic grease.

SAFETY INFORMATION

⚠ CAUTION

Batteries normally produce explosive gases that can cause personal injury. Therefore, do not allow flames, sparks, or lit tobacco to come near battery. When charging or working near a battery, always cover your face and protect your eyes, and also provide ventilation.



- Batteries contain sulfuric acid that burns skin, eyes, and clothing.
- Disconnect the battery before removing or replacing any electrical components.

⚠ WARNING

Gasoline is highly flammable and gasoline vapor is explosive. Never smoke while working on vehicle. Keep all open flames away from gasoline tanks and lines. Wipe up any spilled gasoline immediately.

When tightening fasteners, refer to Torque Chart for the recommended fastener values.

Torque Chart

NC FASTENER TORQUE (FT-LB)			
DIAMETER- THREADS PER INCH	GRADE		
			
	G2	G5	G8
1/4 - 20	6	9	13
5/16 - 18	11	18	28
3/8 - 16	19	31	46
7/16 - 14	30	50	75
1/2 - 13	45	75	115
9/16 - 12	66	110	165
5/8 - 11	93	150	225
3/4 - 10	150	250	370
7/8 - 9	150	378	591
1 - 8	220	583	893
METRIC GRADE 8.8			
M 6	7	M 12	60
M 8	17	M 14	95
M 10	35	M 16	155

SAFETY INFORMATION

Please become familiar with the Warning and Caution labels on the spreader!

Gasoline Warning Label

⚠ WARNING

Gasoline is flammable.

- Turn off engine and allow it to cool before filling gas tank.
- DO NOT smoke or use open flame within 25 feet of spreader.
- Allow spilled gas to evaporate completely before starting engine.
- Gasoline engine produces poisonous gases while running.
DO NOT operate in an enclosed area.
- Gasoline engine has hot and moving parts that can cause injury. Use care when working with or near the gasoline engine and its parts.
- Shut off engine when not in use, even for short periods of time, to avoid damage to equipment or property.

W65097/F9131

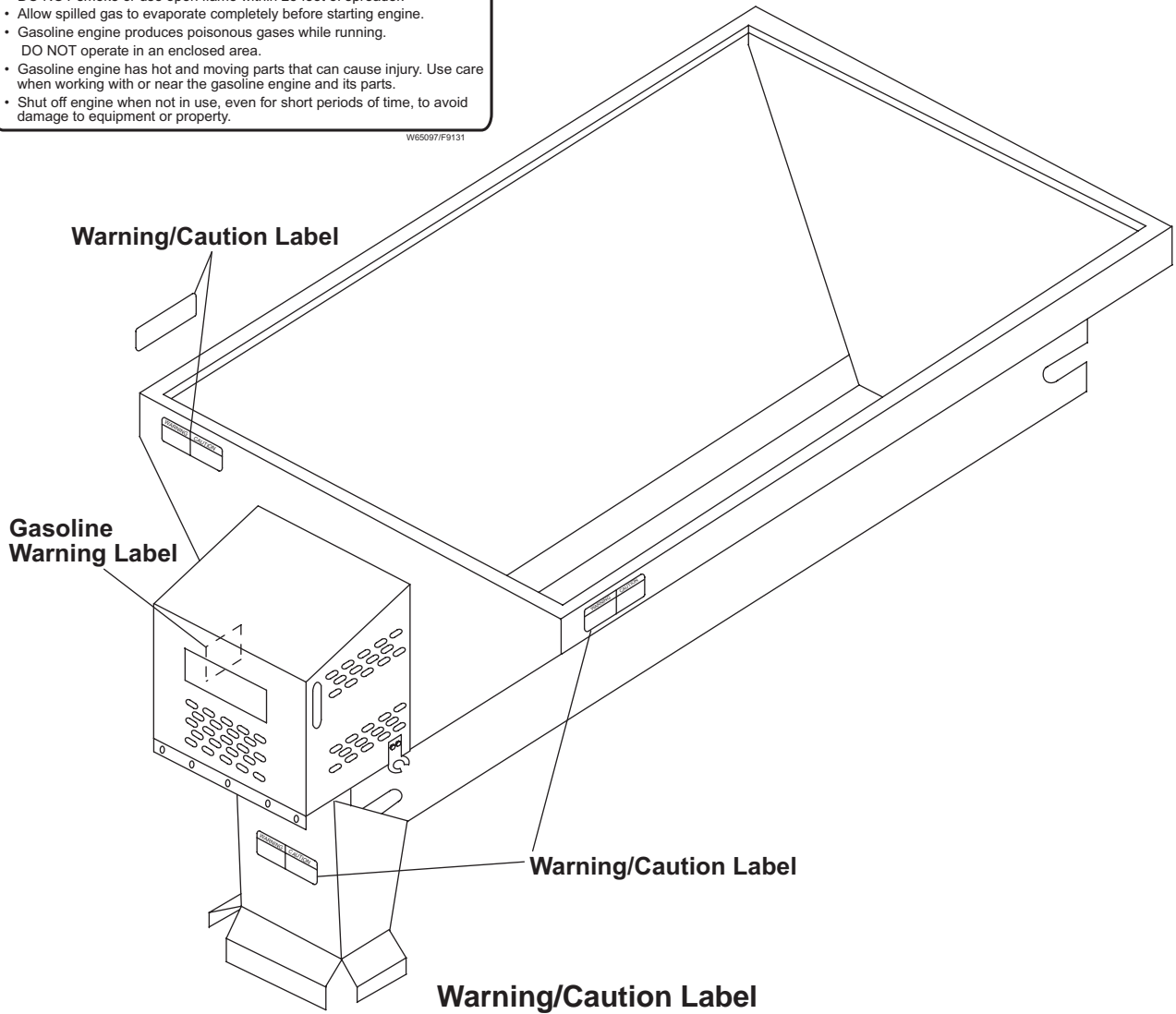

⚠ WARNING	⚠ CAUTION
<ul style="list-style-type: none"> • DO NOT EXCEED GVWR OR GAWR WITH SPREADER AND LOAD. • TURN OFF SPREADER BEFORE FILLING, ADJUSTING, OR CLEANING. • BYSTANDERS TO STAY A MINIMUM OF 25 FEET AWAY FROM OPERATING SPREADER. • DO NOT CLIMB INTO OR RIDE ON SPREADER. • KEEP HANDS, FEET, CLOTHING AWAY FROM MOVING CONVEYOR AND SPINNER. 	<ul style="list-style-type: none"> • READ OWNER'S MANUAL AND ENGINE MANUAL BEFORE OPERATING OR SERVICING SPREADER. • EMPTY AND CLEAN SPREADER AFTER EACH USE.

68595

LOADING

This Manual covers vehicles which have been recommended for carrying the hopper spreader. Please see your local dealer for proper vehicle applications.

Certification

NOTE: All new untitled vehicle installations require National Highway Traffic Safety Administration (NHTSA) Altered Vehicle Certification Labeling. Installer to verify struck load of snow or ice control material does not exceed vehicle GVWR or GAWR ratings.

⚠ WARNING

Overloading could result in an accident or damage. Do not exceed GVWR or GAWR as found on the driver-side cornerpost of vehicle.

Material Weights

Material	Weight (lb. per cubic yd.)
Fine Salt - Dry	2,025
Coarse Salt - Dry	1,431
Coarse Sand - Dry	2,700
Coarse Sand - Wet	3,240
Cinders	1,080

Regular Capacity Load Weight

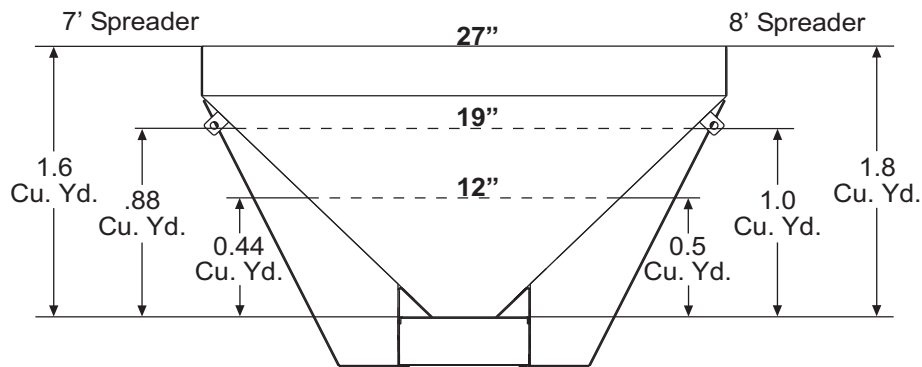

High Capacity Load Weight

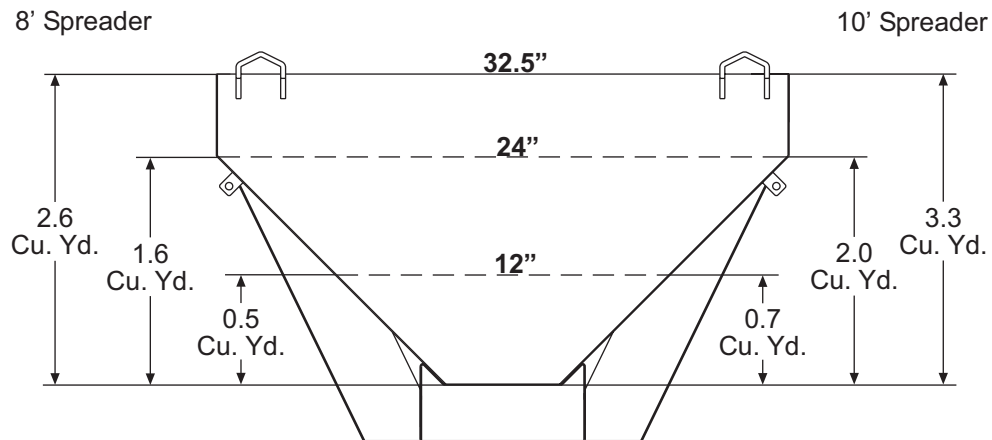

LOADING

Spreader Specifications

Spreader Description	Overall Spreader Length (inches)	Empty Weight (lb.) (No screen or battery)	Capacity Struck (cu. yd.)	Capacity Rounded (cu. yd.)	Overall Width (inches)	Overall Height (inches)	Recommended Use
Regular Capacity 7' Hopper Body 16 Gauge Stainless Steel	101	560	1.6	2.1	50-3/4	32-1/2	3/4 or 1 Ton Pick-up Trucks above 8500 lb. GVWR
Regular Capacity 7' Hopper Body 12 Gauge Mild Steel	101	651	1.6	2.1	50-3/4	32-1/2	
Regular Capacity 8' Hopper Body 16 Gauge Stainless Steel	113	600	1.8	2.3	50-3/4	32-1/2	3/4 or 1 Ton Pick-up Trucks above 8500 lb. GVWR
Regular Capacity 8' Hopper Body 12 Gauge Mild Steel	113	764	1.8	2.3	50-3/4	32-1/2	
High Capacity 8' Hopper Body 12 Gauge Stainless Steel	113	720	2.6	3.2	58	41	Dump or Flat Bed Trucks Above 15,000 lb. GVWR
High Capacity 10' Hopper Body 12 Gauge Stainless Steel	137	984	3.3	4.1	58	41	
High Capacity 8' Hopper Body 12 Gauge Mild Steel	113	786	2.6	3.2	58	41	Dump or Flat Bed Trucks Above 15,000 lb. GVWR
High Capacity 10' Hopper Body 12 Gauge Mild Steel	137	870	3.3	4.1	58	41	
Regular Capacity - Hyd 8' Hopper Body 16 Gauge Stainless Steel	113	455	1.8	2.3	50-3/4	32-1/2	3/4 or 1 Ton Pick-up Trucks Above 8500 lb. GVWR
Regular Capacity - Hyd 8' Hopper Body 12 Gauge Mild Steel	113	610	1.8	2.3	50-3/4	32-1/2	
High Capacity – Hyd 8' Hopper Body 12 Gauge Stainless Steel	113	620	2.6	3.2	58	41	Dump or Flat Bed Trucks Above 15,000 lb. GVWR
High Capacity – Hyd 10' Hopper Body 12 Gauge Stainless Steel	137	878	3.3	4.1	58	41	
High Capacity - Hyd 8' Hopper Body 12 Gauge Mild Steel	113	656	2.6	3.2	58	41	Dump or Flat Bed Trucks Above 15,000 lb. GVWR
High Capacity - Hyd 10' Hopper Body 12 Gauge Mild Steel	137	734	3.3	4.1	58	41	

LOADING

Determining Vehicle Payload

WARNING

Overloading could result in an accident or damage. Do not exceed GVWR or GAWR ratings as found on the driver-side door cornerpost of the vehicle. See Loading Section to determine maximum volumes of spreading material.

1. Install hopper spreader and optional equipment according to the instructions.
2. Install or attach any other equipment that will be on the vehicle while the hopper spreader will be in use (step bumper, trailer hitch, snowplows, etc.). Fill gas tanks.
3. Obtain the Gross Vehicle Weight Rating (GVWR), Front Gross Axle Weight Rating (FGAWR), and Rear Gross Axle Weight Rating (RGAWR) from the certification label located inside the driver-side door jam.
4. With the occupants in the truck for normal hopper spreader operation, weigh the vehicle to obtain gross vehicle weight (GVW).
5. Subtract the GVW from the GVWR to determine the available material payload.
6. Obtain the weight per cubic yard (lb./cu. yd.) of the desired material. Divide the weight into the payload to determine the maximum volume of material that can be carried.
7. Compare the maximum volume to determine the maximum height of the material in the hopper spreader.
8. Fill hopper with the material to the calculated height. Re-weigh vehicle with occupants and verify the GVW, Front Gross Axle Weight, and Rear Gross Axle Weight are less than the vehicle's ratings.
9. Repeat steps 7 and 8 for each type of material.

Refer to "Determining Vehicle Payload" worksheet for an example and worksheet.

LOADING

Determining Vehicle Payload

Material Type	Example: Coarse Salt - Dry				
Equipment installed when vehicle was weighed	RC Mild Steel 8' Hopper Spreader				
Front Gross Axle Weight Rating (FGAWR)					
Rear Gross Axle Weight Rating (RGAWR)					
Gross Vehicle Weight Rating (GVWR) (lb.)	8600				
Gross Vehicle Weight Rating (lb.) (empty)	- 6500				
Payload Available (lb.)	= 2100				
Material Weight (lb./cu. yd.)	+ 1431				
Maximum Volume (cu. yd.)	= 1.47				
Maximum Height (approximate) (in.)	24"				
Loaded Front Gross Axle Weight (FGAW) (lb.)					
Loaded Rear Gross Axle Weight (RGAW) (lb.)					
Loaded Gross Vehicle Weight (GVW)					

OPERATING THE SPREADER - STANDARD CAB CONTROL

Cab Control Identification

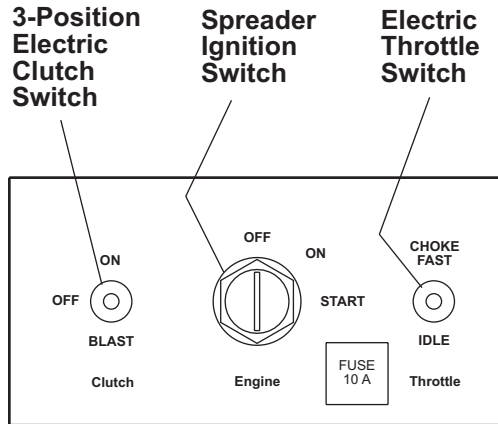

NOTE: The conveyor and spinner will operate when the clutch switch is in the ON or BLAST position.

Engine Operation

Refer to above drawing as a reference for starting and stopping the engine.

Starting the Engine

⚠ CAUTION

Read Owner's and Engine Manual before operating or servicing spreader.

1. Verify the clutch switch is OFF.
2. Turn the vehicle ignition switch to ON.
3. Turn the spreader ignition switch (labeled "Engine" on the cab control) to ON.
4. Move the throttle switch to IDLE and hold for two seconds; release.
5. Move the spreader ignition switch to START.
6. While the engine is cranking, move the throttle switch to CHOKE/FAST.
7. When the engine starts to fire, move the throttle switch towards the idle position. The engine will then start.

8. When the engine starts, release the ignition switch.
9. After the engine starts, move the throttle switch toward FAST to bring the engine up to maximum speed. Allow the engine to warm up to proper operating temperature before attempting to spread.

NOTE: DO NOT hold the throttle switch in the FAST position until the choke re-engages. The engine will not run with the choke 100% engaged. See Choke Adjustment Procedure for instructions for tuning the maximum choke point.

10. To control the engine speed:

- *Increase:* hold the throttle switch at CHOKE/FAST.
- *Decrease:* hold the throttle switch at SLOW.

NOTE: If the engine does not start after 10 seconds of cranking, turn both vehicle and spreader ignition switches to OFF and refer to the engine manual that is shipped with the spreader.

NOTE: Maximum engine speed is obtained just prior to choking the engine.

Stopping the Engine

1. Move the throttle to IDLE and hold for two seconds.
2. Turn the spreader ignition switch to OFF.

⚠ CAUTION

DO NOT leave unused material in hopper. Material can freeze or solidify, causing unit to not work properly. Empty and clean after each use.

⚠ CAUTION

Do not attempt to free the chain by using a pipe wrench or any other tool on the output shaft of the gear case. The gear case is designed to accept torque from the input shaft only. Attempts to turn the output shaft will strip the gears and void any warranty.

OPERATING THE SPREADER - PREMIUM CAB CONTROL

Cab Control Identification

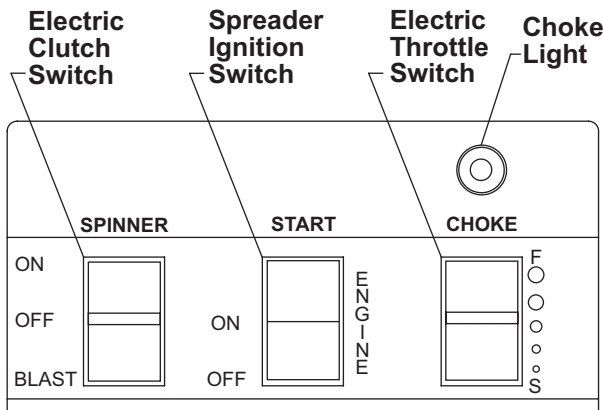

NOTE: The conveyor and spinner will operate when the spinner switch is in the ON or BLAST position.

Engine Operation

Refer to above drawing as a reference for starting and stopping the engine.

Starting the Engine

⚠ CAUTION

Read Owner's and Engine Manual before operating or servicing spreader.

1. Turn the vehicle ignition switch to ON.
2. Verify the spinner switch is OFF.
3. Move the spreader ignition switch to START.
4. While the engine is cranking, move the throttle switch to CHOKE/FAST. (Choke light will come on when the choke begins to close. Hold in FAST for 1/2 second after light comes on.)
5. When the engine starts to fire, move the throttle switch towards the SLOW position. The engine will then start.

6. When the engine starts, release the ignition switch.
7. After the engine starts, move the throttle switch toward FAST to bring the engine up to maximum speed. Allow the engine to warm up to proper operating temperature before attempting to spread.

NOTE: DO NOT hold the throttle switch in the FAST position until the choke re-engages. The engine will not run with the choke 100% engaged. See Choke Adjustment Procedure for instructions for tuning the maximum choke point.

8. To control the engine speed:

- *Increase:* hold the throttle switch at CHOKE/FAST. Do not operate engine with choke light on.
- *Decrease:* hold the throttle switch at SLOW.

NOTE: If the engine does not start after 10 seconds of cranking, turn both vehicle and spreader ignition switches to OFF and see the engine manual that is shipped with the spreader.

NOTE: Maximum engine speed is obtained just prior to choking the engine.

Stopping the Engine

1. Move the throttle to SLOW and hold for two seconds.
2. Turn the spreader ignition switch to OFF.

⚠ CAUTION

DO NOT leave unused material in hopper. Material can freeze or solidify, causing unit to not work properly. Empty and clean after each use.

⚠ CAUTION

Do not attempt to free the chain by using a pipe wrench or any other tool on the output shaft of the gear case. The gear case is designed to accept torque from the input shaft only. Attempts to turn the output shaft will strip the gears and void any warranty.

OPERATING THE SPREADER

Choke Adjustment Procedure

1. The choke linkage and choke adjustment screw is shipped from the factory with the choke butterfly set to **75% fully closed choke**.
2. With the choke set at 100% the engine will not stay running in the choked position. This position is for *extremely* cold conditions. Throttle linkage travel from 0% to 100% choke is 3/16". Four and one-half turns of the Choke Adjustment Screw (clockwise when viewed from above the engine) will take the maximum choke setting from fully closed to fully open (no choking at all).
3. To adjust your choke setting loosen the adjustment retainer screw and rotate the Choke Adjustment Screw clockwise one full turn (scratch a mark on the knob to indicate position). This will generally allow the engine to run very roughly with the throttle linkage at maximum choke. This is approximately the equivalent of 75% fully closed choke. **(This is the factory setting.)**

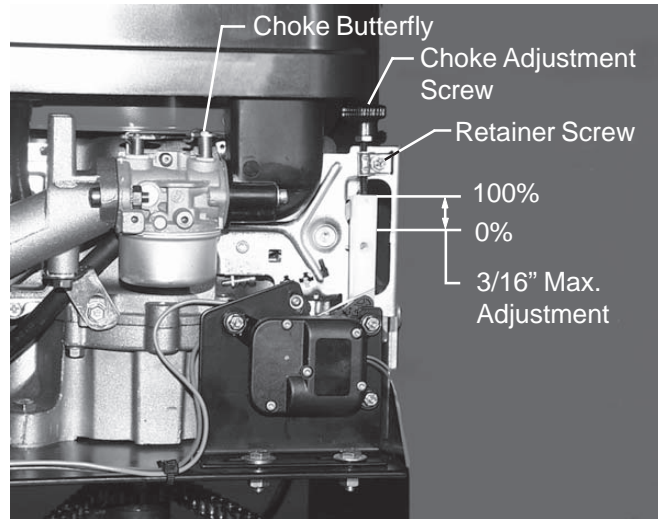

4. Additional adjustments can be made by 1/4 turn increments until you reach the desired start/run in choke setting of your preference/need.

Clutch Operation

1. Start the engine.
2. Adjust the speed to slightly above idle.
3. Move the clutch switch to ON.

⚠ CAUTION

To prevent premature spinner chain failure and chain tension loss, engage the electric clutch at the lowest possible RPM without stopping the engine.

4. Increase the engine speed to the desired RPM.

Baffle Adjustment

Spread pattern and the amount of material dispensed depends on engine RPM, gate position, and baffle settings.

- *Decreasing* RPM and/or gate-opening will *decrease* the amount of material coming to the spinner.
- *Increasing* RPM and/or gate-opening will *increase* the amount of material coming to the spinner.

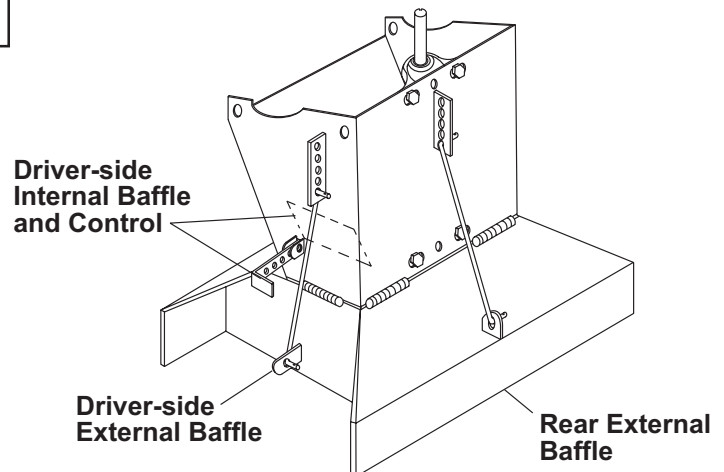

OPERATING THE SPREADER

Spread Patterns

These figures are as viewed from the top of the spinner looking down.

Internal Baffles

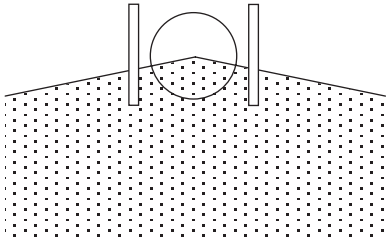

Both internal baffles out

External Baffles

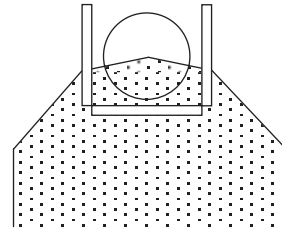

All baffles adjusted down for a confined spread pattern

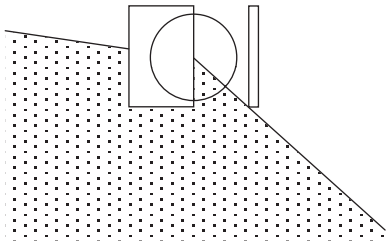

Driver-side baffle in, curb-side baffle out

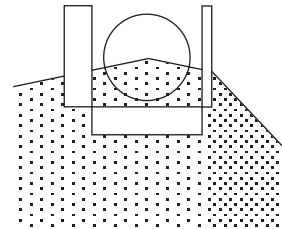

Curb-side baffle deflects material down;
heavy on curb side

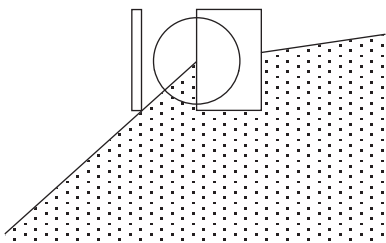

Driver-side baffle out, curb-side baffle in

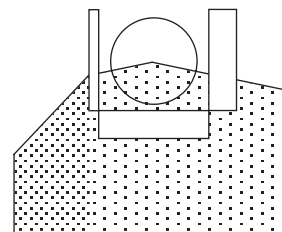

Driver-side baffle deflects material down;
heavy on driver side

MAINTENANCE

Grease

⚠ CAUTION

Over-greasing may cause seal damage. The gear case must be filled to the oil-level plug with SAE 90 gear-type lubricant. Keep the breather plug clean.

- Use dielectric grease on all electrical connections at the beginning and end of each season, and as required during the season.
- After every 10 hours of operation, grease the idler bearings on the idler shaft, flanged bearings on the drive shaft and the input shaft above the gearcase, and the spinner shaft bearings.
- After every 50 hours of operation, grease the input shaft bearing on the gear case and verify the oil level of the gear case is level with the fill hole.
- Change gear case oil once a year. Drain oil by removing the side cover of the gear case. Refill with SAE 90 weight gear oil. Oil level should be even with the bottom of the fill hole.

Chains

- At the beginning of each season, and once a month during the season, verify the drive sprocket and spinner sprocket set screws are tight.

⚠ CAUTION

Over-tightening the roller chains may damage the bearings on the gear case, the engine, and/or the spinner shaft. Over-tightening will also shorten the life of the roller chain and of the sprockets.

- Maintain spinner shaft-to-gear case roller chain tension. Correct chain tension allows 5/16" deflection midway between the sprockets.
To increase chain tension: loosen the bearing mounting hardware and pull the spinner shaft away from the gear case. Make sure the spinner shaft is vertical and the sprockets are lined up before re-tightening the fasteners. Oil this chain after each use and at the end of each season.

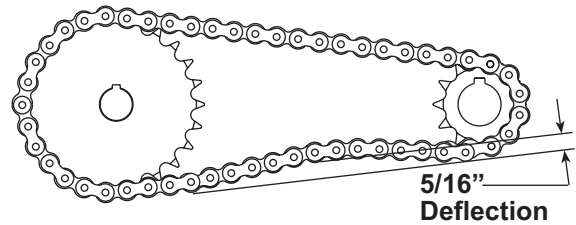

- Maintain engine-to-electric clutch roller chain tension. Correct tension allows 5/16" deflection midway between the sprockets.
To increase chain tension: loosen the four engine mount-to-engine base bolts and pull the engine away from the electric clutch. Re-tighten bolts. Oil this chain after each use and at the end of each season.

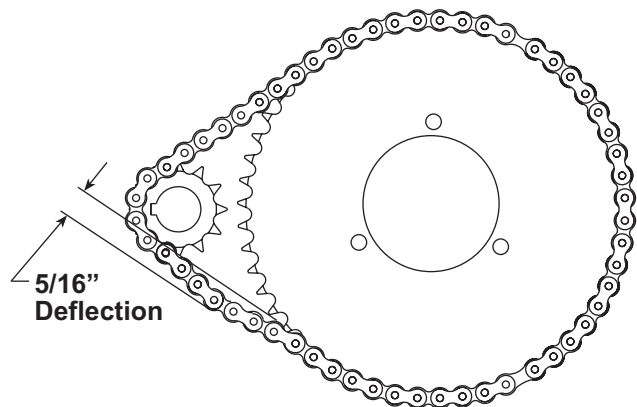

MAINTENANCE

- Periodically check the conveyor chain tension. To check the tension, measure in 20"-24" from the rear edge of the sills. Push up on the chain with your hand. The conveyor chain should lift up 1"-3" off the conveyor chain guide or cross angles.

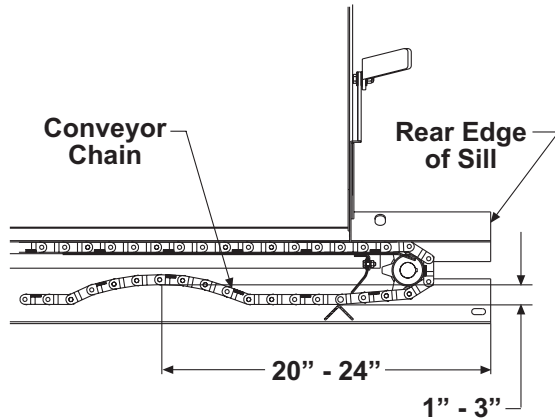

- Use the two 5/8" x 6" take-up bolts at the front of the spreader to adjust the conveyor chain tension. Turn both sides equal amounts to ensure the tension is equally distributed across both sides of the conveyor chain.
- Always empty the spreader when it is not in use to prevent a frozen conveyor chain.

Electric Clutch

To minimize problems and extend the life of the electric clutch, do the following:

- At the end of each snow season, remove and clean the clutch.
- After cleaning the clutch, coat both mating surfaces of the clutch with oil or light grease.
- Remove oil and grease prior to using the clutch again.

Fuel Filter Replacement

Replace the fuel filter before each season.

- Remove clamps from existing fuel filter.
- Remove existing fuel filter.
- Install new filter with arrow pointing toward carburetor.
- Replace and tighten clamps
- Check for fuel leaks.

Engine Service and Repair

Maintain the spreader engine according to the engine Owner's Manual that is shipped with the spreader. Engine warranty is covered by the engine manufacturer and is described in the engine manual.

If service or repair is needed, contact an authorized engine manufacturer service center. To serve you promptly, the service center will need the make, model, type, and code number for your engine.

Your nearest service center is listed in the "Yellow Pages" under "Engines, Gasoline" or "Gasoline Engines."

NOTE: The maximum choke point of the Tecumseh Engine is adjustable. The unit is shipped with the choke adjusted to be 75% closed. See Choke Adjustment Procedure for adjustment instructions.

HYDRAULIC HOPPER SPREADER MAINTENANCE

Hydraulic Hopper Spreaders

1. Check hydraulic fluid level before every use. Add fluid as required.
 2. Periodically inspect the hoses and fittings for damage and possible leaks.
 3. Change the hydraulic fluid after the first 50 hours of operation of a new unit.
 4. Reservoir should be drained through the drain plug only, NOT through the suction outlet.
- Flush and refill reservoir annually, or sooner if fluid shows signs of break-down or contamination.
 - The use of proper hydraulic fluid in the system is critical to satisfactory performance. Only clean, new hydraulic fluid, of the proper type and viscosity, should be used.
 - Keep all hydraulic fluids in original containers. Use only clean measuring containers and funnels when pouring fluids. Keep all containers closed when not in use.

⚠ CAUTION

Always disconnect electric power before servicing or performing any maintenance.

To keep your spreader functioning properly, observe the following recommendations:

After each use:

- Wash out hopper and rinse off all external surfaces.
- Apply dielectric grease to all electrical connections to prevent corrosion.
- Lubricate all grease fittings.

At the end of each season:

- Wash out hopper and all external surfaces.
- Apply dielectric grease to all electrical connections to prevent corrosion.
- Lubricate all grease fittings.
- Oil or paint all bare metal surfaces.

PROBLEM	CORRECTION
1. Unit speed does not increase with the dial setting.	A. Increase the truck engine speed. B. Check condition of pump. C. Check for adequate PTO percent.
2. Unit stalls under load.	Check circuit pressure. 900-1200 PSI maximum with relief valve lifting at 1500 PSI.
3. Unit speed fluctuates momentarily when control is first turned on.	A. Oil is cold. Wait until oil has warmed up. B. Change to lighter weight oil.
4. Pump blows seals at start up.	Pump installed backwards. Replace seals and reverse pump in driveline. (Note arrow on pump.)

WIRING DIAGRAM (SPREADER BATTERY KIT)

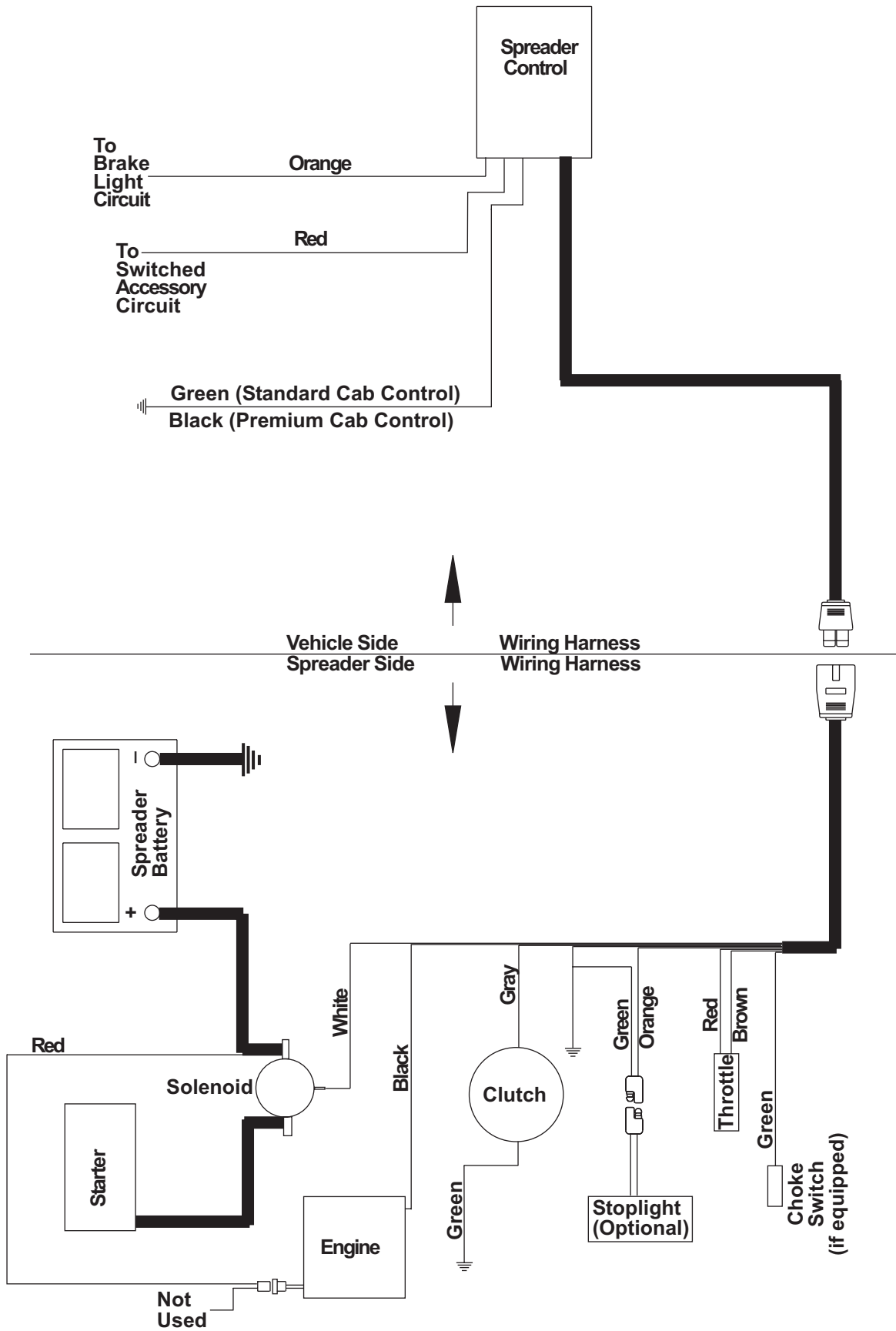

WIRING DIAGRAM (VEHICLE BATTERY KIT)

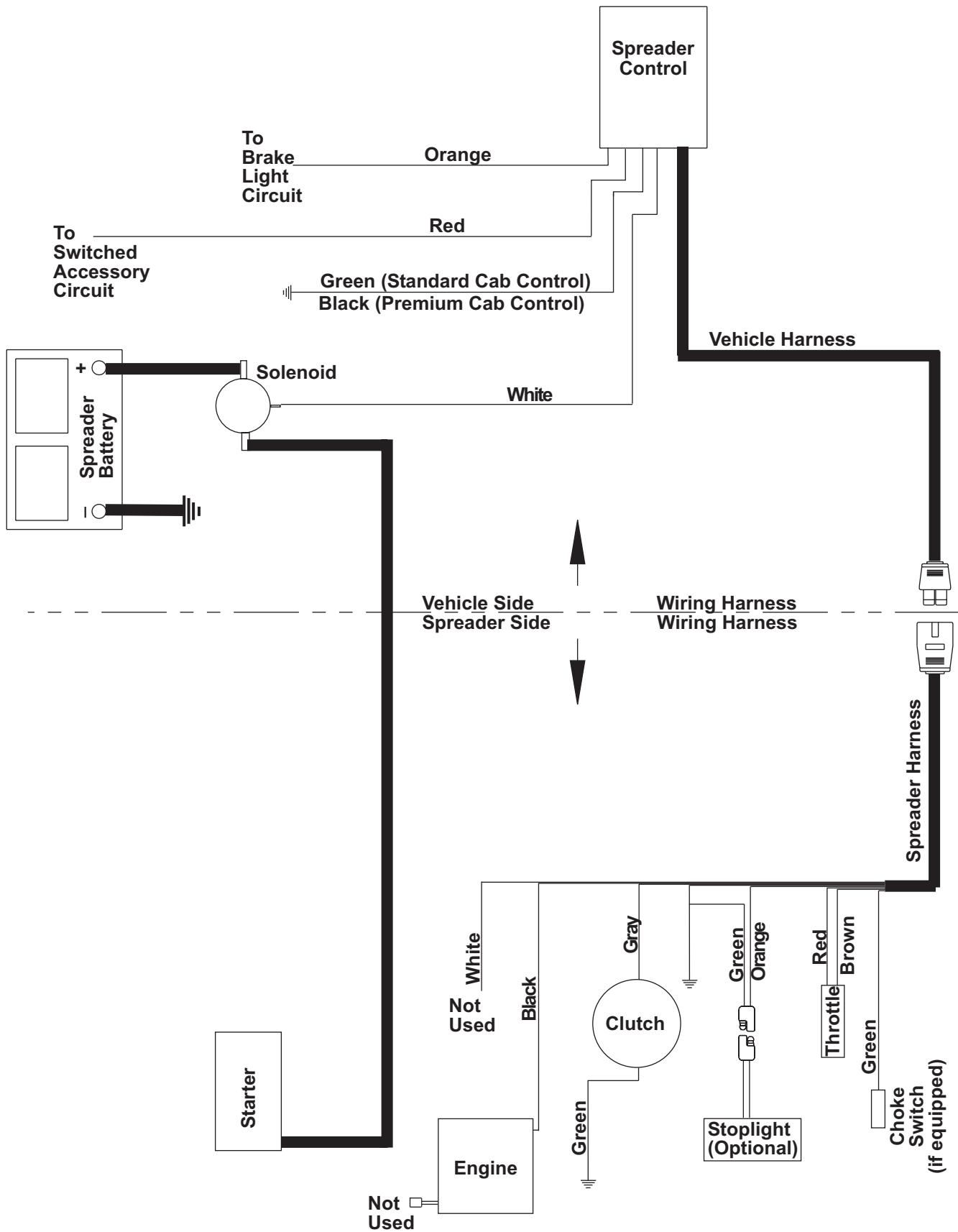

ELECTRIC THROTTLE MOTOR REPLACEMENT

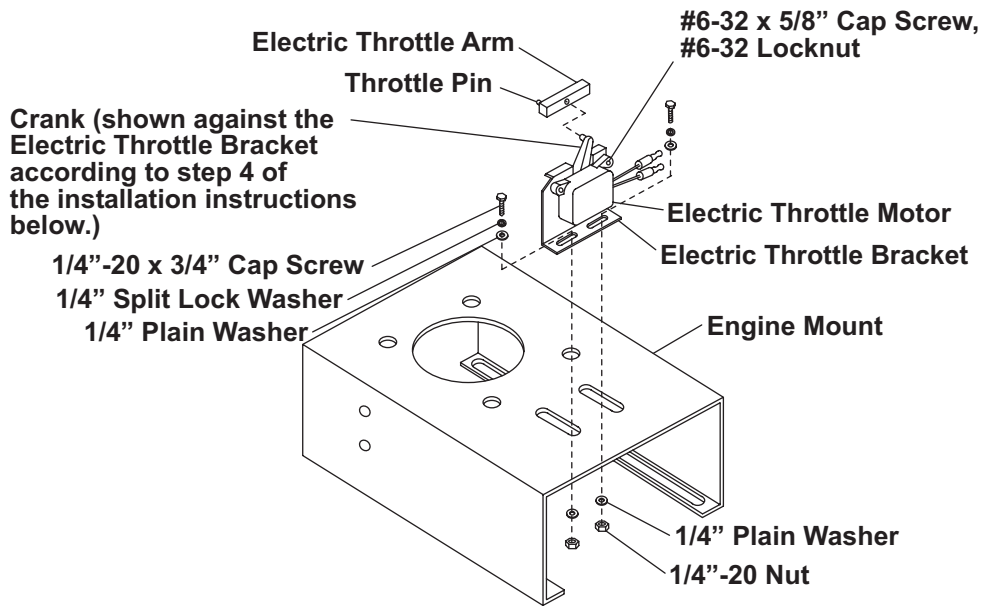

Removal Instructions

1. Disconnect the battery cables.
2. Carefully observe the existing installation. Mark the electric throttle position on the engine mount.
3. Disconnect the brown and red spreader harness wires from the electric throttle motor leads.
4. Remove the 1/4"-20 fasteners that hold the electric throttle bracket to the engine mount.
5. Remove the #6-32 fasteners holding the electric throttle motor to the bracket. Remove the electric throttle motor.
6. Place the electric throttle assembly onto the engine mount inserting the throttle pin into the engine choke/throttle linkage plastic slider (not shown).
7. Loosely bolt electric throttle assembly to the engine mount with the existing hardware.
8. Keeping the electric throttle arm parallel to and against the carburetor control bracket, move the electric throttle bracket forward putting the engine throttle into the full choke position.
9. Tighten the fasteners according to the Torque Chart.
10. Reconnect the battery cables.
11. Verify the crank is stopped in both directions by the bracket, not the carburetor linkage.

Installation Instructions

⚠ CAUTION

Improper installation can result in damage to the engine choke/throttle linkage.

1. Connect the brown and red spreader harness wires (not shown) to the corresponding colored electric throttle motor leads.
2. Using the electric throttle control, run the new motor until the crank reaches the 12 o'clock position. (A 9-volt battery can be used as a substitute for the control.)
3. Fasten the electric throttle motor to the bracket using the existing hardware.
4. Using the electric throttle control, run the new electric throttle motor until the crank is against the bracket as shown in above diagram.
5. Place the electric throttle arm on the crank as shown in the above diagram.
6. Place the electric throttle assembly onto the engine mount inserting the throttle pin into the engine choke/throttle linkage plastic slider (not shown).
7. Loosely bolt electric throttle assembly to the engine mount with the existing hardware.
8. Keeping the electric throttle arm parallel to and against the carburetor control bracket, move the electric throttle bracket forward putting the engine throttle into the full choke position.
9. Tighten the fasteners according to the Torque Chart.
10. Reconnect the battery cables.
11. Verify the crank is stopped in both directions by the bracket, not the carburetor linkage.



FISHER ENGINEERING
P.O. BOX 529
ROCKLAND, MAINE 04841

 A DIVISION OF DOUGLAS DYNAMICS, L.L.C.

Copyright© 2000 Douglas Dynamics, L.L.C. All rights reserved. This material may not be reproduced or copied, in whole or in part, in any printed, mechanical, electronic, film or other distribution and storage media, without the written consent of Fisher Engineering. Authorization to photocopy items for internal or personal use by Fisher Engineering outlets is granted.

Fisher Engineering reserves the right under its product improvement policy to change construction or design details and furnish equipment when so altered without reference to illustrations or specifications used herein. Fisher Engineering and the vehicle manufacturer may require and/or recommend optional equipment for hopper spreaders. Fisher Engineering offers a limited warranty for all hopper spreaders and accessories. See separately printed page for this important information. The following is a registered® trademark of Douglas Dynamics, L.L.C.: FISHER® .

Printed in USA

Lit. No. 68880

April 1, 2000